

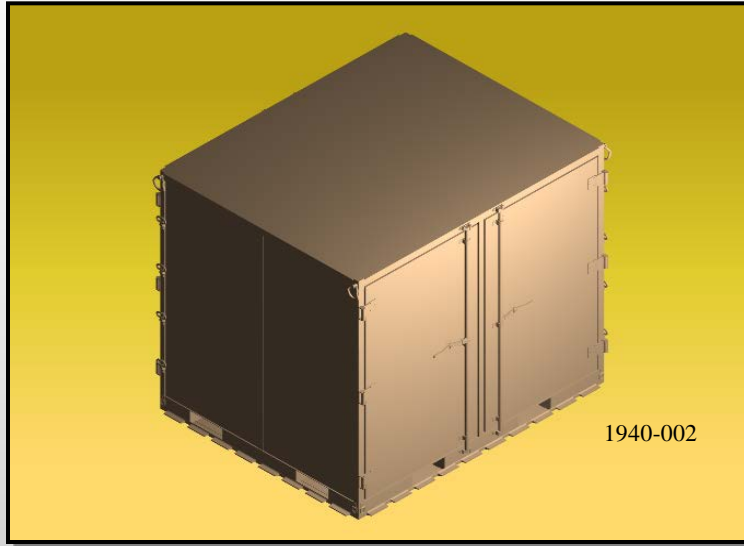

# Highland Engineering, Inc.

1153 Grand Oaks Drive ■ Howell, MI 48843  
(517) 548-4372 ■ (517) 548-4423 (Fax)

## EAC 90 Standard *(four doors, two on each long side)*



### Characteristics

- Overall dimensions - 88"wd x 108"lg x 90"ht
- Interior Cube - 394 cubic ft
- Shipping Cube - 495 cubic ft
- Tare weight – 1,750 lbs
- Capacity - 10,000 lbs
- Gross - 11,750 lbs

- P/N 1940-001 (green) or P/N 1940-002 (tan)
- Four doors (two on each 108" side)
- Fork-liftable from all sides
- Integral 463/L compatible base rails
- Winching rings at base corners
- Anti-racking door locks
- Multi purpose lifting/tiedown provisions at upper corners
- Flat bottom provided for roller conveyor mobility
- Center posts with slam-latch disconnect
- Roof access steps provided
- Standard shelf supports provided



### OPTIONAL ACCESSORIES AVAILABLE:

Shelf Assembly.....2100-001  
 Divider Panel Assembly.....2200-001  
 Caster Assembly.....2300-001  
 Haz-Mat door(s).....2500-001

Dehumidifiers:  
 Factory Installed .....2400-001  
 Field Installed.....2400-002

*Custom configurations available*

### CERTIFICATIONS

NOTE: Certification for Internal Air Lift has been granted by ATTLA. External Air Lift certification is pending.

[www.high-eng.com](http://www.high-eng.com)





# Highland Engineering, Inc.

1153 Grand Oaks Drive ■ Howell, MI 48843  
(517) 548-4372 ■ (517) 548-4423 (Fax)

## EAC 90 Stock (four doors, two on each short side)

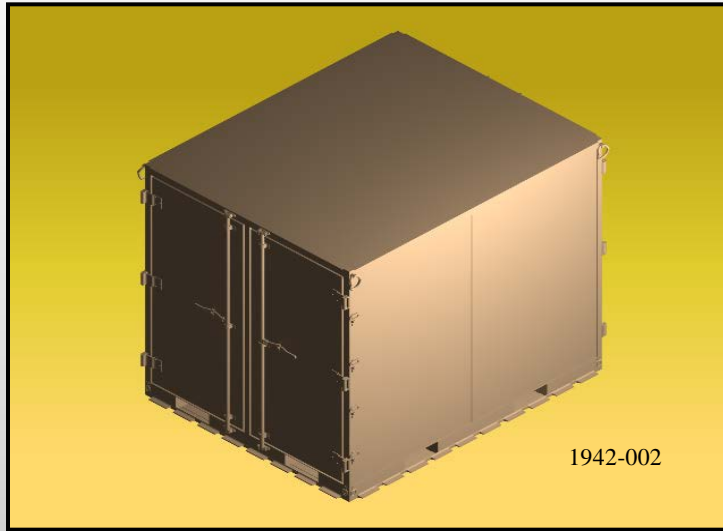

### Characteristics

- Overall dimensions - 88"wd x 108"lg x 90"ht
- Interior Cube - 391 cubic ft
- Shipping Cube - 495 cubic ft
- Tare weight – 1,750 lbs
- Capacity - 10,000 lbs
- Gross - 11,750 lbs

- P/N 1942-001 (green) or P/N 1942-002 (tan)
- Four doors (two on each 88" side)
- Fork-liftable from all sides
- Integral 463/L compatible base rails
- Winching rings at base corners
- Anti-racking door locks
- Multi purpose lifting/tiedown provisions at upper corners
- Flat bottom provided for roller conveyor mobility
- Center posts with slam-latch disconnect
- Roof access steps provided
- Standard shelf supports provided

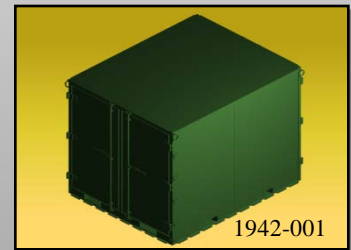

### OPTIONAL ACCESSORIES AVAILABLE:

Shelf Assembly.....2100-003  
 Divider Panel Assembly.....2200-002  
 Caster Assembly.....2300-001  
 Haz-Mat door(s).....2500-001

Dehumidifiers:  
 Factory Installed .....2400-001  
 Field Installed.....2400-002

Custom configurations available

### CERTIFICATIONS

NOTE: Certification for Internal Air Lift has been granted by ATTILA. External Air Lift certification is pending.





# Highland Engineering, Inc.

1153 Grand Oaks Drive ■ Howell, MI 48843  
(517) 548-4372 ■ (517) 548-4423 (Fax)

## EAC 90 Stock/Standard Open

(two doors, two on one short side for Stock & two on long side for Standard)

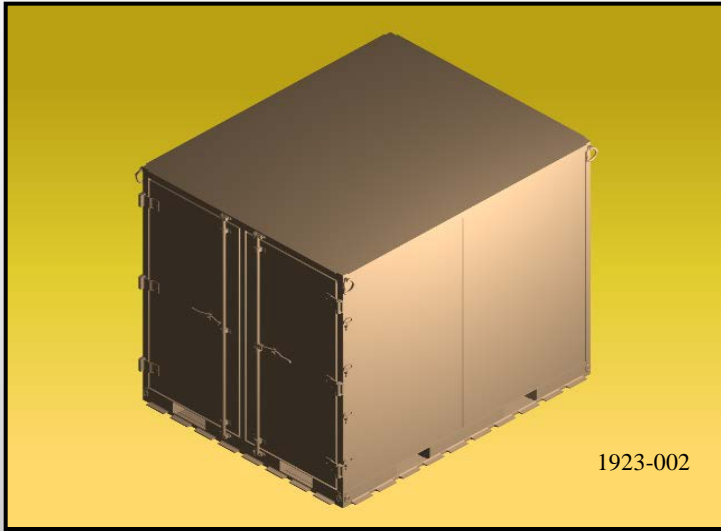

1923-002

### Characteristics

- Overall dimensions - 88"wd x 108"lg x 90"ht
- Interior Cube - 395 cubic ft
- Shipping Cube - 495 cubic ft
- Tare weight - 1,650 lbs
- Capacity - 10,000 lbs\*  
\*5,000 lbs restrained
- Gross - 11,650 lbs

- Stock P/N 1923-001 (green) or P/N 1923-002 (tan)  
- Two doors (two on one 88" side)
- Standard P/N 1923-010 (green) or P/N 1923-012 (tan)  
- Two doors (two on 108" side)
- Fork-liftable from all sides
- Integral 463/L compatible base rails
- Winching rings at base corners
- Anti-racking door locks
- Multi purpose lifting/tiedown provisions at upper corners
- Flat bottom provided for roller conveyor mobility
- Center post with slam-latch disconnect
- Roof access steps provided



1923-001



1923-011

### OPTIONAL ACCESSORIES AVAILABLE:

Caster Assembly.....2300-001  
 Haz-Mat door(s).....2500-001

#### Dehumidifiers:

Factory Installed .....2400-001  
 Field Installed.....2400-002

Custom configurations available

### CERTIFICATIONS

NOTE: Certification for Internal Air Lift has been granted by ATTLA. External Air Lift certification has been granted by US Army. Shock test certified by US Navy.

[www.high-eng.com](http://www.high-eng.com)





# Highland Engineering, Inc.

1153 Grand Oaks Drive ■ Howell, MI 48843  
(517) 548-4372 ■ (517) 548-4423 (Fax)

## EAC 90 Slant (four doors, two on each long side)

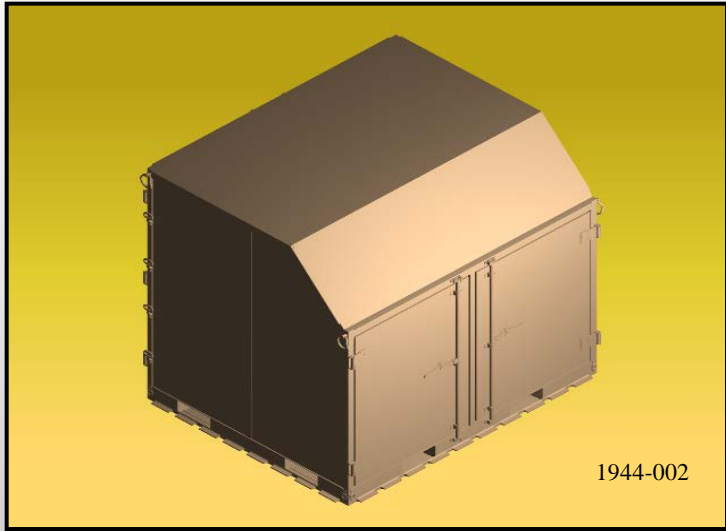

### Characteristics

- Overall dimensions - 88"wd x 108"lg x 90"ht
- Interior Cube - 377 cubic ft
- Shipping Cube - 495 cubic ft
- Tare weight – 1,770 lbs
- Capacity - 10,000 lbs
- Gross - 11,770 lbs

- P/N 1944-001 (green) or P/N 1944-002 (tan)
- Four doors (two on each 108" side)
- Fork-liftable from all sides
- Integral 463/L compatible base rails
- Winching rings at base corners
- Anti-racking door locks
- Multi purpose lifting/tiedown provisions at upper corners
- Flat bottom provided for roller conveyor mobility
- Center posts with slam-latch disconnect
- Roof access steps provided
- Standard shelf supports provided



### OPTIONAL ACCESSORIES AVAILABLE:

Shelf Assembly.....2100-001  
 Divider Panel Assembly....2200-001 & 2200-003  
 Caster Assembly.....2300-001  
 Haz-Mat door(s).....2500-001

Dehumidifiers:  
 Factory Installed .....2400-001  
 Field Installed.....2400-002

Custom configurations available

### CERTIFICATIONS

NOTE: Certification for Internal Air Lift has been granted by ATTLA. External Air Lift certification is pending.

[www.high-eng.com](http://www.high-eng.com)





# Highland Engineering, Inc.

1153 Grand Oaks Drive ■ Howell, MI 48843  
(517) 548-4372 ■ (517) 548-4423 (Fax)

## EAC 90 Aisle Slant (four doors, two on each long side)

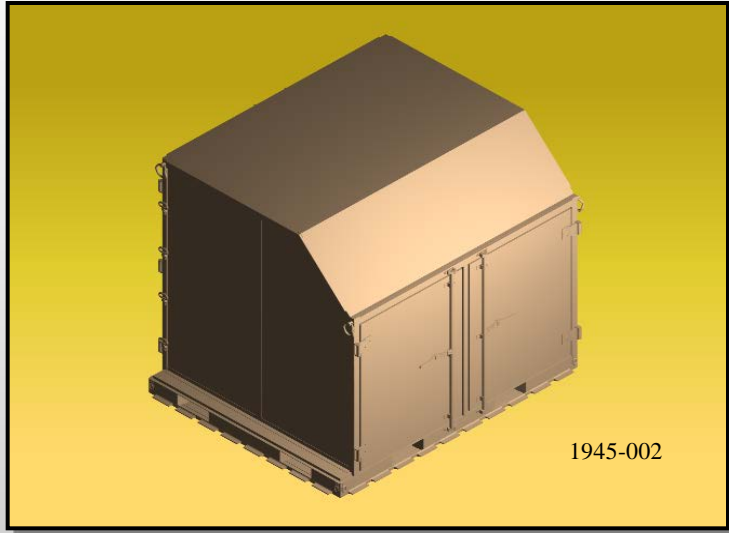

### Characteristics

- Overall dimensions - 88"wd x 108"lg x 90"ht
- Interior Cube - 355 cubic ft
- Shipping Cube - 495 cubic ft
- Tare weight – 1,770 lbs
- Capacity - 10,000 lbs
- Gross - 11,770 lbs

- P/N 1945-001 (green) or P/N 1945-002 (tan)
- Four doors (two on each 108" side)
- Fork-liftable from all sides
- Integral 463/L compatible base rails
- Winching rings at base corners
- Anti-racking door locks
- Multi purpose lifting/tiedown provisions at upper corners
- Flat bottom provided for roller conveyor mobility
- Center posts with slam-latch disconnect
- Roof access steps provided
- Standard shelf supports provided



### OPTIONAL ACCESSORIES AVAILABLE:

Shelf Assembly.....2100-002  
 Divider Panel Assembly....2200-001 & 2200-003  
 Caster Assembly.....2300-001  
 Haz-Mat door(s).....2500-001

Dehumidifiers:  
 Factory Installed .....2400-001  
 Field Installed.....2400-002

Custom configurations available

### CERTIFICATIONS

NOTE: Certification for Internal Air Lift has been granted by ATTILA. External Air Lift certification is pending.

[www.high-eng.com](http://www.high-eng.com)





# Highland Engineering, Inc.

1153 Grand Oaks Drive ■ Howell, MI 48843  
(517) 548-4372 ■ (517) 548-4423 (Fax)

## EAC 90 Aisle (four doors, two on each long side)

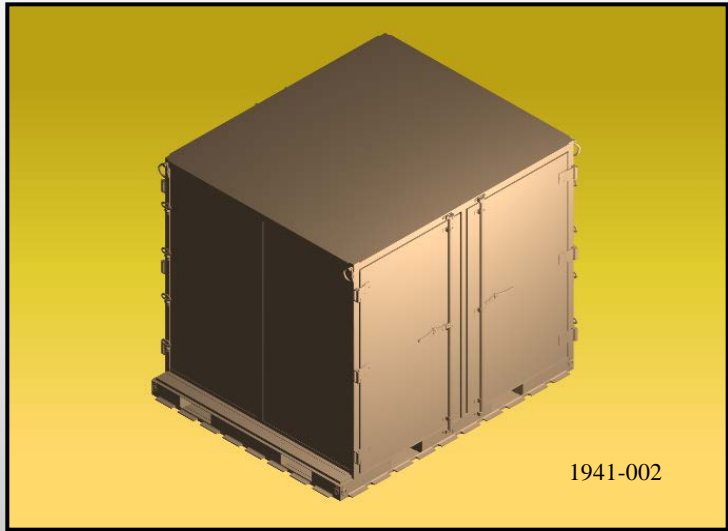

- Characteristics**
- Overall dimensions - 88"wd x 108"lg x 90"ht
  - Interior Cube - 368 cubic ft
  - Shipping Cube - 495 cubic ft
  - Tare weight – 1,750 lbs
  - Capacity - 10,000 lbs
  - Gross - 11,750 lbs

- P/N 1941-001 (green) or P/N 1941-002 (tan)
- Four doors (two on each 108" side)
- Fork-liftable from all sides
- Integral 463/L compatible base rails
- Winching rings at base corners
- Anti-racking door locks
- Multi purpose lifting/tiedown provisions at upper corners
- Flat bottom provided for roller conveyor mobility
- Center posts with slam-latch disconnect
- Roof access steps provided
- Standard shelf supports provided



### OPTIONAL ACCESSORIES AVAILABLE:

- Shelf Assembly.....2100-002
- Divider Panel Assembly.....2200-001
- Caster Assembly.....2300-001
- Haz-Mat door(s).....2500-001

- Dehumidifiers:
- Factory Installed .....2400-001
- Field Installed.....2400-002

Custom configurations available

### CERTIFICATIONS

NOTE: Certification for Internal Air Lift has been granted by ATTLA. External Air Lift certification is pending.





# Highland Engineering, Inc.

1153 Grand Oaks Drive ■ Howell, MI 48843  
(517) 548-4372 ■ (517) 548-4423 (Fax)

## EAC 80 Standard *(four doors, two on each long side)*

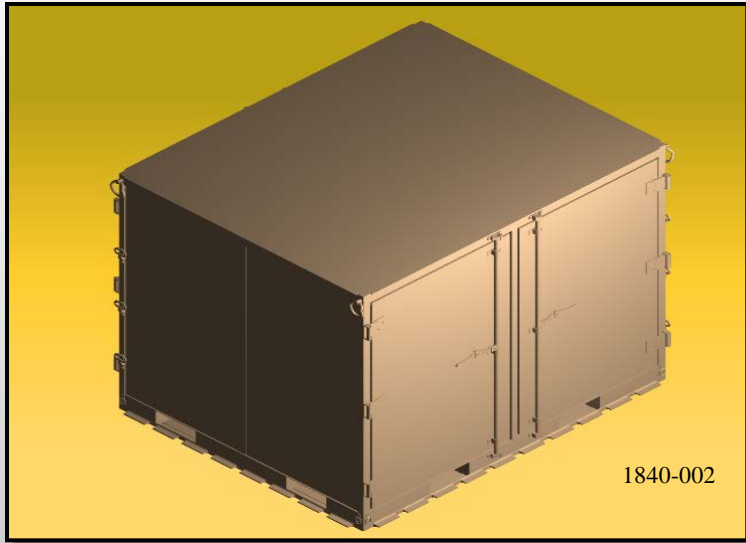

### Characteristics

- Overall dimensions - 88"wd x 108"lg x 80"ht
- Interior Cube - 344 cubic ft
- Shipping Cube - 440 cubic ft
- Tare weight – 1,660 lbs
- Capacity - 10,000 lbs
- Gross - 11,660 lbs

- P/N 1840-001 (green) or P/N 1840-002 (tan)
- Four doors (two on each 108" side)
- Fork-liftable from all sides
- Integral 463/L compatible base rails
- Winching rings at base corners
- Anti-racking door locks
- Multi purpose lifting/tiedown provisions at upper corners
- Flat bottom provided for roller conveyor mobility
- Center posts with slam-latch disconnect
- Roof access steps provided
- Standard shelf supports provided

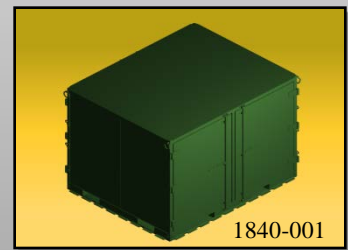

### OPTIONAL ACCESSORIES AVAILABLE:

Shelf Assembly.....2100-001  
 Divider Panel Assembly.....2200-004  
 Caster Assembly.....2300-001  
 Haz-Mat door(s).....2500-001

Dehumidifiers:  
*Factory Installed* .....2400-001  
*Field Installed*.....2400-002

*Custom configurations available*

### CERTIFICATIONS

NOTE: Certification for Internal Air Lift has been granted by ATTILA. External Air Lift certification is pending.

[www.high-eng.com](http://www.high-eng.com)





# Highland Engineering, Inc.

1153 Grand Oaks Drive ■ Howell, MI 48843  
(517) 548-4372 ■ (517) 548-4423 (Fax)

## EAC 80 Aisle (four doors, two on each long side)

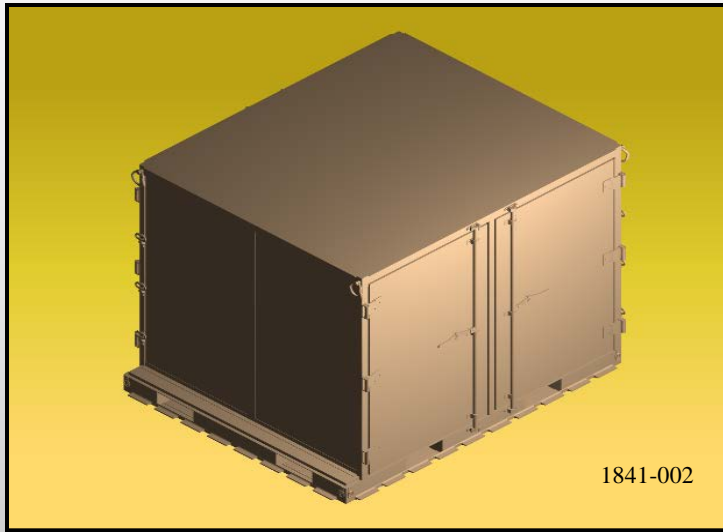

### Characteristics

- Overall dimensions - 88"wd x 108"lg x 80"ht
- Interior Cube - 323 cubic ft
- Shipping Cube - 440 cubic ft
- Tare weight – 1,660 lbs
- Capacity - 10,000 lbs
- Gross - 11,660 lbs

- P/N 1841-001 (green) or P/N 1841-002 (tan)
- Four doors (two on each 108" side)
- Fork-liftable from all sides
- Integral 463/L compatible base rails
- Winching rings at base corners
- Anti-racking door locks
- Multi purpose lifting/tiedown provisions at upper corners
- Flat bottom provided for roller conveyor mobility
- Center posts with slam-latch disconnect
- Roof access steps provided
- Standard shelf supports provided



### OPTIONAL ACCESSORIES AVAILABLE:

Shelf Assembly.....2100-002  
 Divider Panel Assembly.....2200-004  
 Caster Assembly.....2300-001  
 Haz-Mat door(s).....2500-001

Dehumidifiers:  
 Factory Installed .....2400-001  
 Field Installed.....2400-002

Custom configurations available

### CERTIFICATIONS

NOTE: Certification for Internal Air Lift has been granted by ATTILA. External Air Lift certification is pending.

[www.high-eng.com](http://www.high-eng.com)







# Highland Engineering, Inc.

1153 Grand Oaks Drive ■ Howell, MI 48843  
(517) 548-4372 ■ (517) 548-4423 (Fax)

## EAC 80 Stock (four doors, two on each short side)

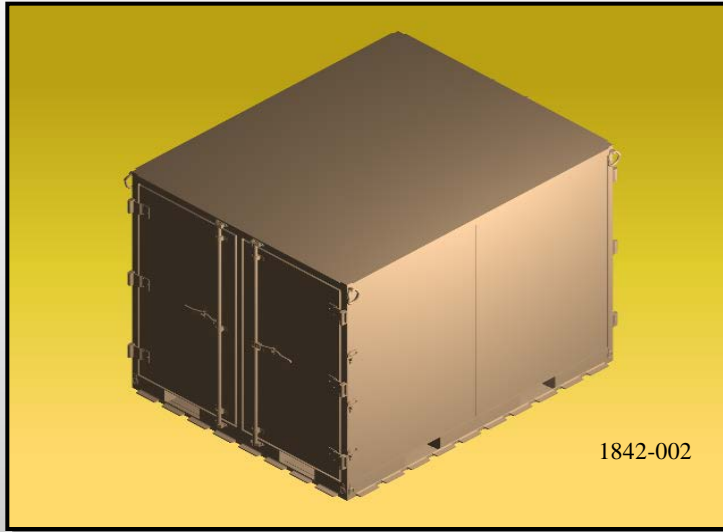

### Characteristics

- Overall dimensions - 88"wd x 108"lg x 80"ht
- Interior Cube - 344 cubic ft
- Shipping Cube - 440 cubic ft
- Tare weight – 1,660 lbs
- Capacity - 10,000 lbs
- Gross - 11,660 lbs

- P/N 1842-001 (green) or P/N 1842-002 (tan)
- Four doors (two on each 88" side)
- Fork-liftable from all sides
- Integral 463/L compatible base rails
- Winching rings at base corners
- Anti-racking door locks
- Multi purpose lifting/tiedown provisions at upper corners
- Flat bottom provided for roller conveyor mobility
- Center posts with slam-latch disconnect
- Roof access steps provided
- Standard shelf supports provided



### OPTIONAL ACCESSORIES AVAILABLE:

Shelf Assembly.....2100-003  
 Divider Panel Assembly.....2200-005  
 Caster Assembly.....2300-001  
 Haz-Mat door(s).....2500-001

Dehumidifiers:  
 Factory Installed .....2400-001  
 Field Installed.....2400-002

Custom configurations available

### CERTIFICATIONS

NOTE: Certification for Internal Air Lift has been granted by ATTILA. External Air Lift certification is pending.

[www.high-eng.com](http://www.high-eng.com)





# Highland Engineering, Inc.

1153 Grand Oaks Drive ■ Howell, MI 48843  
(517) 548-4372 ■ (517) 548-4423 (Fax)

## EAC 80 Stock Open *(two doors, two on one short side)*

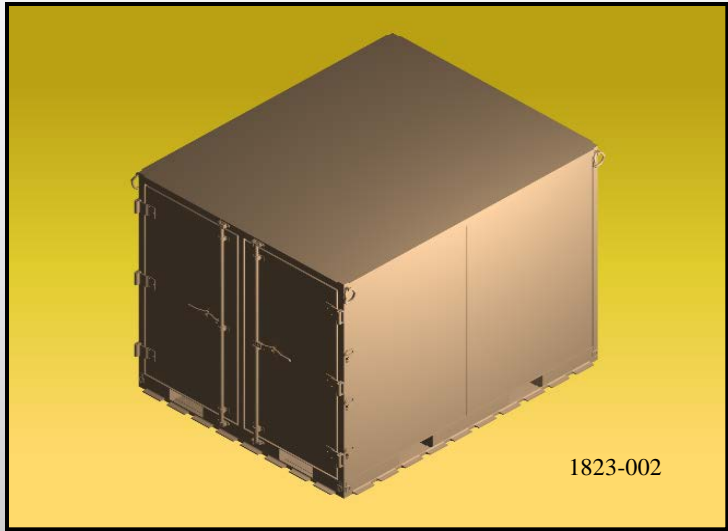

### Characteristics

- Overall dimensions - 88"wd x 108"lg x 80"ht
- Interior Cube - 348 cubic ft
- Shipping Cube - 440 cubic ft
- Tare weight – 1,570 lbs
- Capacity - 10,000 lbs\*  
\*5,000 lbs restrained
- Gross - 11,570 lbs

- P/N 1823-001 (green) or P/N 1823-002 (tan)
- Two doors (two on one 88" side)
- Fork-liftable from all sides
- Integral 463/L compatible base rails
- Winching rings at base corners
- Anti-racking door locks
- Multi purpose lifting/tiedown provisions at upper corners
- Flat bottom provided for roller conveyor mobility
- Center post with slam-latch disconnect
- Roof access steps provided



### OPTIONAL ACCESSORIES AVAILABLE:

Caster Assembly.....2300-001  
 Haz-Mat door(s).....2500-001

Dehumidifiers:  
 Factory Installed .....2400-001  
 Field Installed.....2400-002  
 Custom configurations available

### CERTIFICATIONS

NOTE: Certification for Internal Air Lift has been granted by ATTILA. External Air Lift certification is pending.

[www.high-eng.com](http://www.high-eng.com)





# Highland Engineering, Inc.

1153 Grand Oaks Drive ■ Howell, MI 48843  
(517) 548-4372 ■ (517) 548-4423 (Fax)

## EAC 60 Standard *(four doors, two on each long side)*

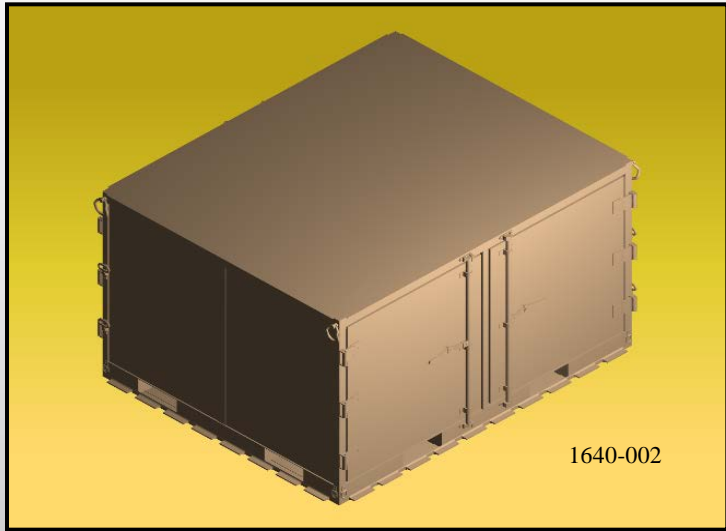

### Characteristics

- Overall dimensions - 88"wd x 108"lg x 60"ht
- Interior Cube - 249 cubic ft
- Shipping Cube - 330 cubic ft
- Tare weight – 1,480 lbs
- Capacity - 10,000 lbs
- Gross - 11,480 lbs

- P/N 1640-001 (green) or P/N 1640-002 (tan)
- Four doors (two on each 108" side)
- Fork-liftable from all sides
- Integral 463/L compatible base rails
- Winching rings at base corners
- Anti-racking door locks
- Multi purpose lifting/tiedown provisions at upper corners
- Flat bottom provided for roller conveyor mobility
- Center posts with slam-latch disconnect
- Roof access steps provided
- Standard shelf supports provided



### OPTIONAL ACCESSORIES AVAILABLE:

Shelf Assembly.....2100-001  
 Divider Panel Assembly.....2200-006  
 Caster Assembly.....2300-001  
 Haz-Mat door(s).....2500-001

Dehumidifiers:  
*Factory Installed* .....2400-001  
*Field Installed*.....2400-002

*Custom configurations available*

### CERTIFICATIONS

NOTE: Certification for Internal Air Lift has been granted by ATTLA. External Air Lift certification is pending.

[www.high-eng.com](http://www.high-eng.com)





# Highland Engineering, Inc.

1153 Grand Oaks Drive ■ Howell, MI 48843  
(517) 548-4372 ■ (517) 548-4423 (Fax)

## EAC 60 Aisle *(four doors, two on each long side)*

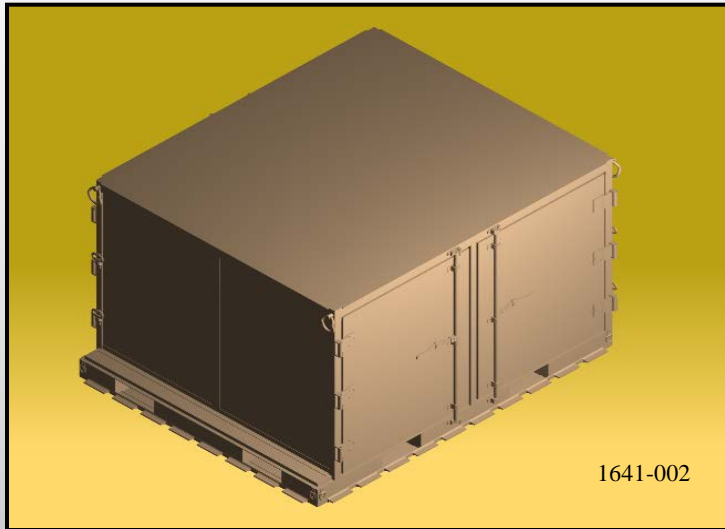

### Characteristics

- Overall dimensions - 88"wd x 108"lg x 60"ht
- Interior Cube - 235 cubic ft
- Shipping Cube - 330 cubic ft
- Tare weight – 1,480 lbs
- Capacity - 10,000 lbs
- Gross - 11,480 lbs

- P/N 1641-001 (green) or P/N 1641-002 (tan)
- Four doors (two on each 108" side)
- Fork-liftable from all sides
- Integral 463/L compatible base rails
- Winching rings at base corners
- Anti-racking door locks
- Multi purpose lifting/tiedown provisions at upper corners
- Flat bottom provided for roller conveyor mobility
- Center posts with slam-latch disconnect
- Roof access steps provided
- Standard shelf supports provided

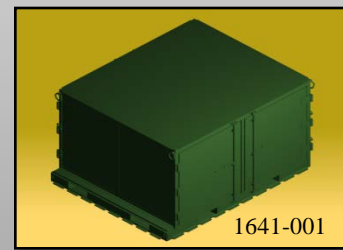

### OPTIONAL ACCESSORIES AVAILABLE:

Shelf Assembly.....2100-002  
 Divider Panel Assembly.....2200-006  
 Caster Assembly.....2300-001  
 Haz-Mat door(s).....2500-001

Dehumidifiers:  
 Factory Installed .....2400-001  
 Field Installed.....2400-002

Custom configurations available

### CERTIFICATIONS

NOTE: Certification for Internal Air Lift has been granted by ATTLA. External Air Lift certification is pending.

[www.high-eng.com](http://www.high-eng.com)





# Highland Engineering, Inc.

1153 Grand Oaks Drive ■ Howell, MI 48843  
(517) 548-4372 ■ (517) 548-4423 (Fax)

## EAC 60 Stock (four doors, two on each short side)

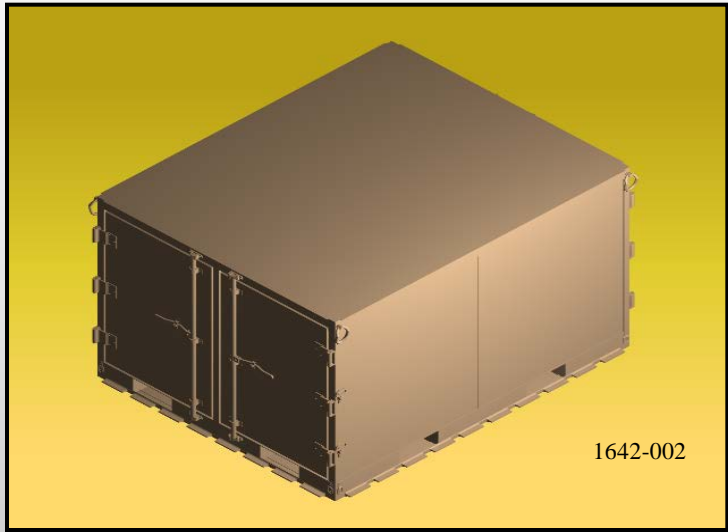

### Characteristics

- Overall dimensions - 88"wd x 108"lg x 60"ht
- Interior Cube - 249 cubic ft
- Shipping Cube - 330 cubic ft
- Tare weight – 1,480 lbs
- Capacity - 10,000 lbs
- Gross - 11,480 lbs

- P/N 1642-001 (green) or P/N 1642-002 (tan)
- Four doors (two on each 88" side)
- Fork-liftable from all sides
- Integral 463/L compatible base rails
- Winching rings at base corners
- Anti-racking door locks
- Multi purpose lifting/tiedown provisions at upper corners
- Flat bottom provided for roller conveyor mobility
- Center posts with slam-latch disconnect
- Roof access steps provided
- Standard shelf supports provided



### OPTIONAL ACCESSORIES AVAILABLE:

Shelf Assembly.....2100-003  
 Divider Panel Assembly.....2200-007  
 Caster Assembly.....2300-001  
 Haz-Mat door(s).....2500-001

Dehumidifiers:  
 Factory Installed .....2400-001  
 Field Installed.....2400-002

Custom configurations available

### CERTIFICATIONS

NOTE: Certification for Internal Air Lift has been granted by ATTLA. External Air Lift certification is pending.

[www.high-eng.com](http://www.high-eng.com)





# Highland Engineering, Inc.

1153 Grand Oaks Drive ■ Howell, MI 48843  
(517) 548-4372 ■ (517) 548-4423 (Fax)

## EAC 70 Slant (four doors, two on each long side)

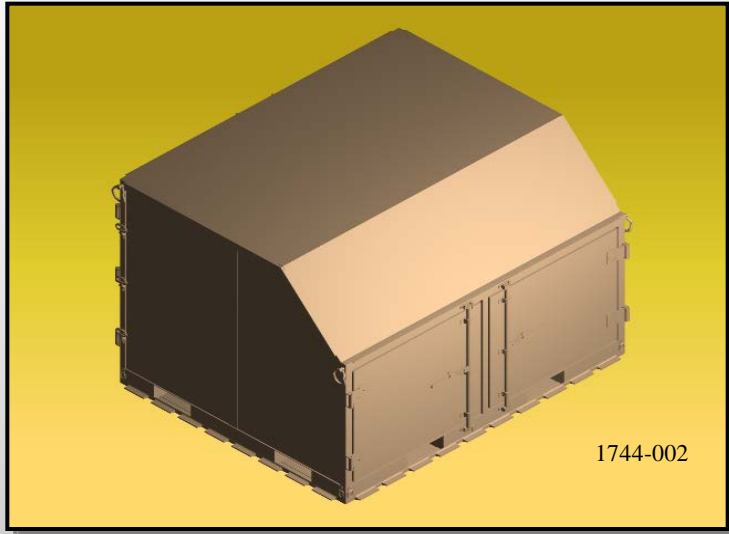

### Characteristics

- Overall dimensions - 88"wd x 108"lg x 70"ht
- Interior Cube - 282 cubic ft
- Shipping Cube - 385 cubic ft
- Tare weight – 1,590 lbs
- Capacity - 10,000 lbs
- Gross - 11,590 lbs

- P/N 1744-001 (green) or P/N 1744-002 (tan)
- Four doors (two on each 108" side)
- Fork-liftable from all sides
- Integral 463/L compatible base rails
- Winching rings at base corners
- Anti-racking door locks
- Multi purpose lifting/tiedown provisions at upper corners
- Flat bottom provided for roller conveyor mobility
- Center posts with slam-latch disconnect
- Roof access steps provided
- Standard shelf supports provided



### OPTIONAL ACCESSORIES AVAILABLE:

Shelf Assembly.....2100-001  
 Divider Panel Assembly....2200-008 & 2200-009  
 Caster Assembly.....2300-001  
 Haz-Mat door(s).....2500-001

Dehumidifiers:  
 Factory Installed .....2400-001  
 Field Installed.....2400-002

Custom configurations available

### CERTIFICATIONS

NOTE: Certification for Internal Air Lift has been granted by ATTILA. External Air Lift certification is pending.

[www.high-eng.com](http://www.high-eng.com)





# Highland Engineering, Inc.

1153 Grand Oaks Drive ■ Howell, MI 48843  
(517) 548-4372 ■ (517) 548-4423 (Fax)

## EAC 70 Aisle Slant *(four doors, two on each long side)*

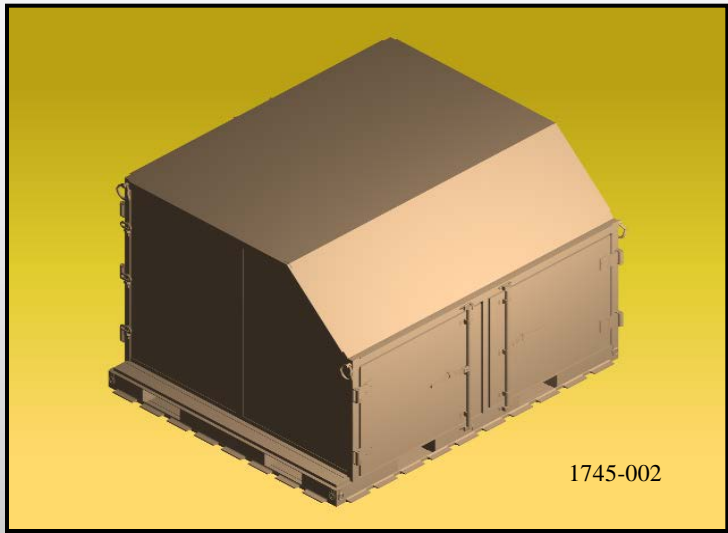

### Characteristics

- Overall dimensions - 88"wd x 108"lg x 70"ht
- Interior Cube - 266 cubic ft
- Shipping Cube - 385 cubic ft
- Tare weight – 1,590 lbs
- Capacity - 10,000 lbs
- Gross - 11,590 lbs

- P/N 1745-001 (green) or P/N 1745-002 (tan)
- Four doors (two on each 108" side)
- Fork-liftable from all sides
- Integral 463/L compatible base rails
- Winching rings at base corners
- Anti-racking door locks
- Multi purpose lifting/tiedown provisions at upper corners
- Flat bottom provided for roller conveyor mobility
- Center posts with slam-latch disconnect
- Roof access steps provided
- Standard shelf supports provided



### OPTIONAL ACCESSORIES AVAILABLE:

Shelf Assembly.....2100-002  
 Divider Panel Assembly....2200-008 & 2200-009  
 Caster Assembly.....2300-001  
 Haz-Mat door(s).....2500-001

Dehumidifiers:  
 Factory Installed .....2400-001  
 Field Installed.....2400-002

*Custom configurations available*

### CERTIFICATIONS

NOTE: Certification for Internal Air Lift has been granted by ATTLA. External Air Lift certification is pending.

[www.high-eng.com](http://www.high-eng.com)

