



# Highland Engineering, Inc.

1153 Grand Oaks Drive ■ Howell, MI 48843  
(517) 548-4372 ■ (517) 548-4423 (Fax)

## EAC 90 Standard Open

(four doors, two on each long side, has no center wall)

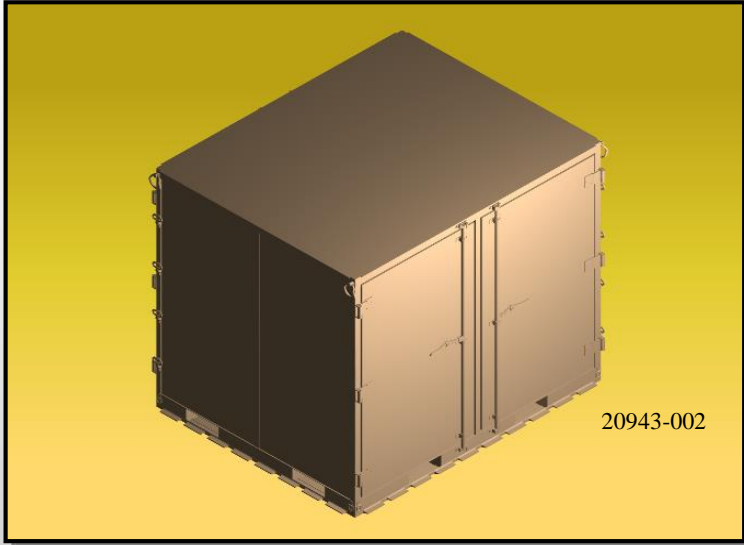

### Characteristics

- Overall dimensions - 88"wd x 108"lg x 90"ht
- Interior Cube - 395 cubic ft
- Shipping Cube - 495 cubic ft
- Tare weight - 1,515 lbs
- Capacity - 10,000 lbs\*  
\*5,000 lbs max unrestrained
- Gross - 11,515 lbs

- P/N 20943-001 (green) or P/N 20943-002 (tan)
- Four doors (two on each 108" side)
- Forkliftable from all sides
- Integral 463L compatible base rails
- Winching rings at base corners
- Anti-racking door locks
- Multi purpose lifting/tiedown provisions at upper corners
- Flat bottom provided for roller conveyor mobility
- Center post with slam-latch disconnect
- Roof access steps
- Interior tie down rings for load restraint

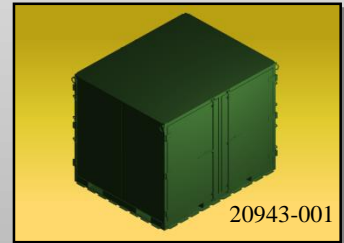

### OPTIONAL ACCESSORIES AVAILABLE:

Caster Assembly.....2300-001  
 Haz-Mat door(s).....2500-001

Dehumidifiers:  
 Factory Installed .....2400-001  
 Field Installed.....2400-002

Custom configurations available

### CERTIFICATIONS

NOTE: Certification for Internal airlift has been granted by ATTLA. External airlift certifiable.

