



Highland Engineering, Inc.

1153 Grand Oaks Drive ■ Howell, MI 48843
(517) 548-4372 ■ (517) 548-4423 (Fax)

EAC 80 Aisle

(four doors, two on each long side, has center wall)

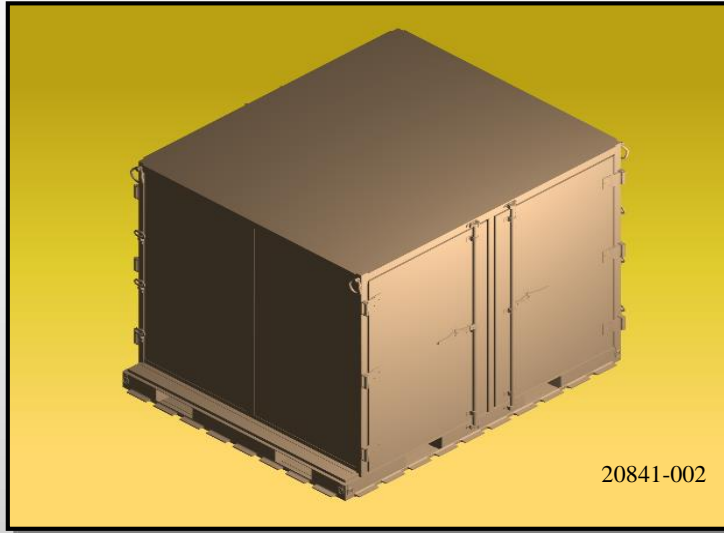

Characteristics

- Overall dimensions - 88"wd x 108"lg x 80"ht
- Interior Cube - 323 cubic ft
- Shipping Cube - 440 cubic ft
- Tare weight – 1,660 lbs
- Capacity - 10,000 lbs
- Gross - 11,660 lbs

- P/N 20841-001 (green) or P/N 20841-002 (tan)
- Four doors (two on each 108" side)
- Forkliftable from all sides
- Integral 463L compatible base rails
- Winching rings at base corners
- Anti-racking door locks
- Multi purpose lifting/tiedown provisions at upper corners
- Flat bottom provided for roller conveyor mobility
- Center posts with slam-latch disconnect
- Roof access steps
- Integrated track for shelving



OPTIONAL ACCESSORIES AVAILABLE:

Shelf Assembly.....2100-002
 Divider Panel Assembly.....2200-004
 Caster Assembly.....2300-001
 Haz-Mat door(s).....2500-001

Dehumidifiers:
 Factory Installed2400-001
 Field Installed.....2400-002

Custom configurations available

CERTIFICATIONS

NOTE: Certification for Internal airlift has been granted by ATTILA. External airlift certifiable.

